

500 NM STANDARD ARM COVERAGE

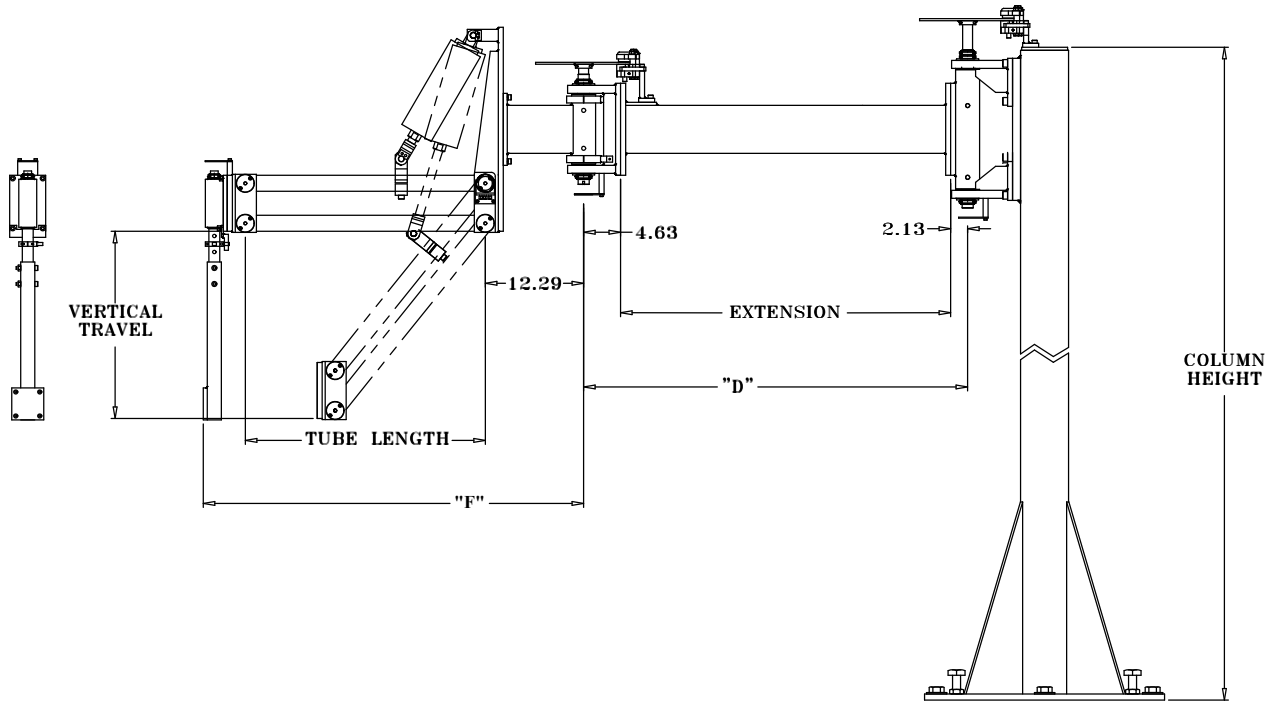

BASIC ARTICULATING ARM										OPTIONS			
MODEL	CYLINDER		EXTENSION		TUBE LENGTH		VERTICAL TRAVEL	REACH DIM. RANGE		PIVOT BRAKE		COLUMN HEIGHT	
								"D"	"F"				
20	1	3.25	1	29.25"	1	24"	18.00"	36"	41.50"	1	W/O BRAKE	1	8' - 96.00"
	2	4.00	2	41.25"	2	30"	22.50"	48"	47.50"	2	W/ BRAKE	2	9' - 108"
	3	5.00	3	53.25"	3	36"	27.00"	60"	53.50"			3	10' - 120"
					4	48"	31.50"		59.50"			4	11' - 132"
												5	12' - 144"

(EXAMPLE PART # 201-1221)

BREAKDOWN OF EXAMPLE PART # 20 1 - 1 2 2 1

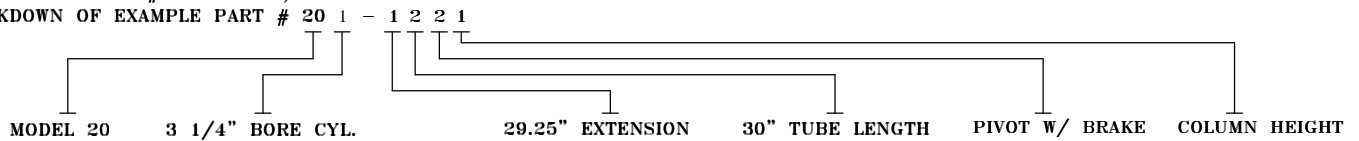

NOTES: 1) NONE.

2) NONE.